

MFOS Brief

By Ray Wilson

Generally useful thing to do with joystick pots. This way you can use the voltage outputs to control whatever voltage controlled modules you have.

Add resistance to the pots to reduce current consumption. The values shown put about 1mA through the 5K pot.

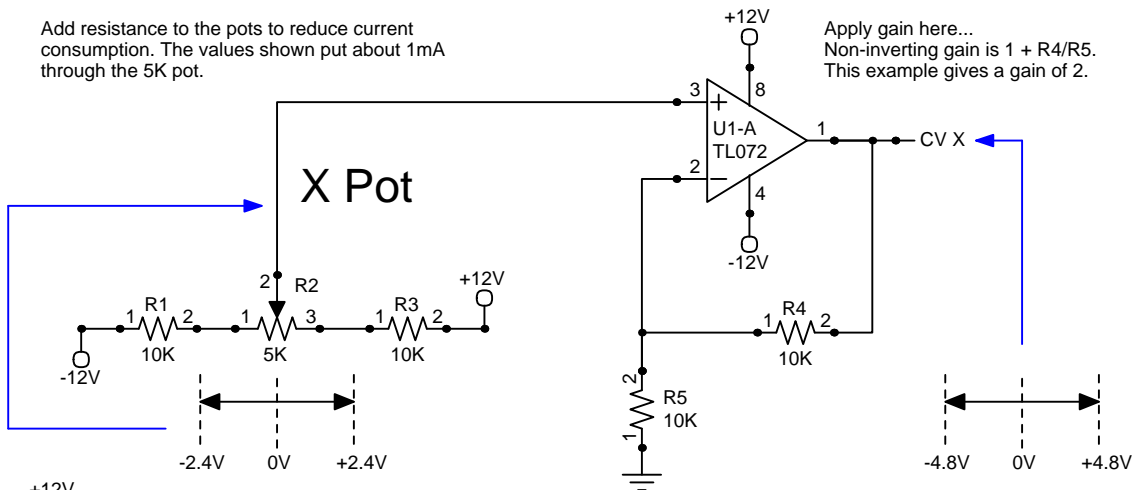

Y Pot

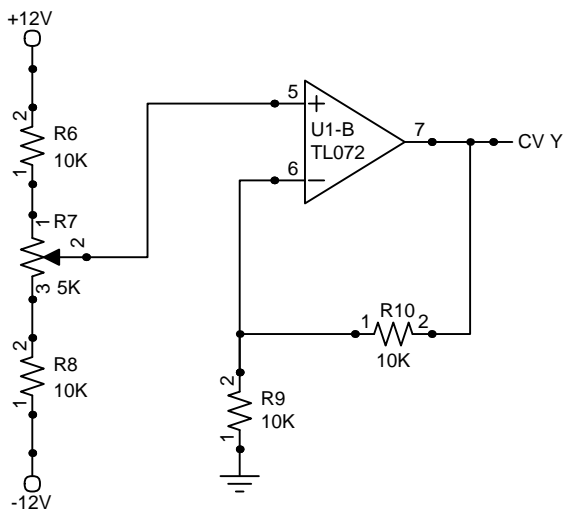

Bipolar output version

Single ended output version

Add resistance to the pots to reduce current consumption. The values shown put about 1mA through the 5K pot.

