

All of these pots are mounted on the front panel of the sequencer. You can use anything from 100K to 500K with little or no noticeable difference in operation.

A higher value for R51 will permit longer maximum portamento times (glide between notes effect). A lower value will cause shorter maximum portamento times.

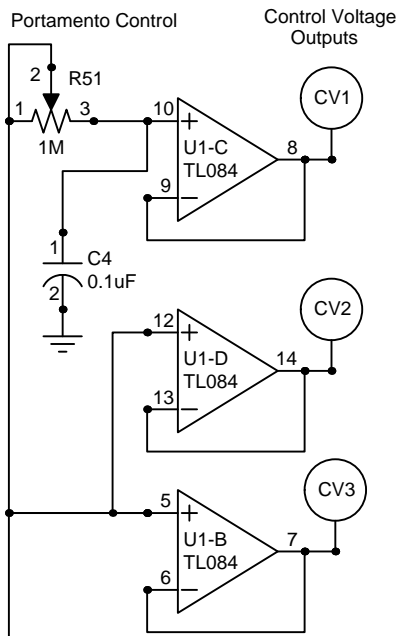

16 Step Analog Sequencer Schematic by Ray Wilson copyright Ray Wilson 2005

To Digital Board