

# Sound Lab Mini-Synth Mark II Voltage Controlled Oscillator 1

Design by Ray Wilson

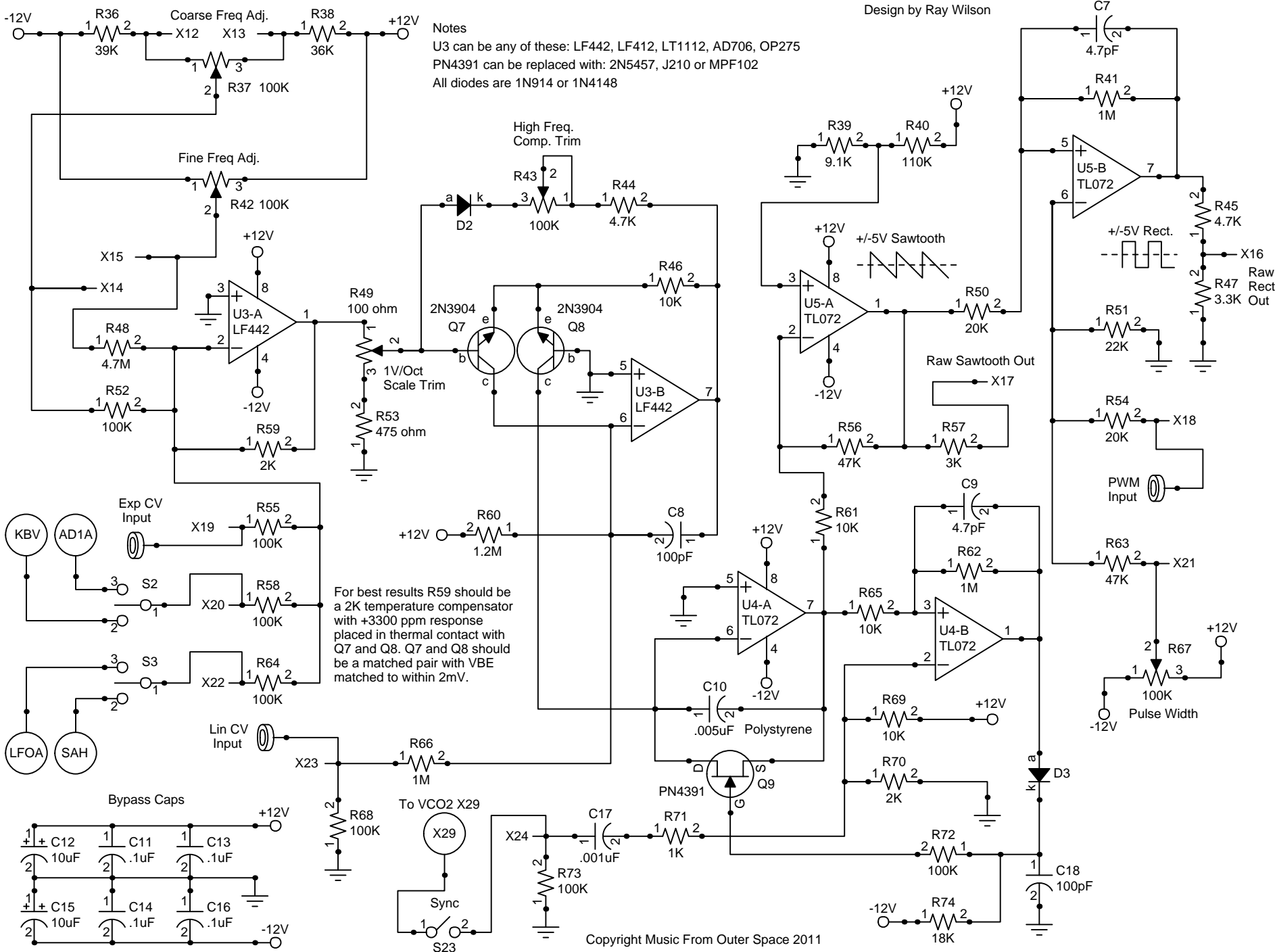

## Notes

- U3 can be any of these: LF442, LF412, LT1112, AD706, OP275
- PN4391 can be replaced with: 2N5457, J210 or MPF102
- All diodes are 1N914 or 1N4148

For best results R59 should be a 2K temperature compensator with +3300 ppm response placed in thermal contact with Q7 and Q8. Q7 and Q8 should be a matched pair with VBE matched to within 2mV.