

MFOS 8 Input (Expandable) Panning Mixer With Two Effect Sends

Designed by: Ray Wilson October 2006

Four (4) mono inputs with up to x10 gain.
Two (2) stereo line level inputs.
Onboard headphone amp.

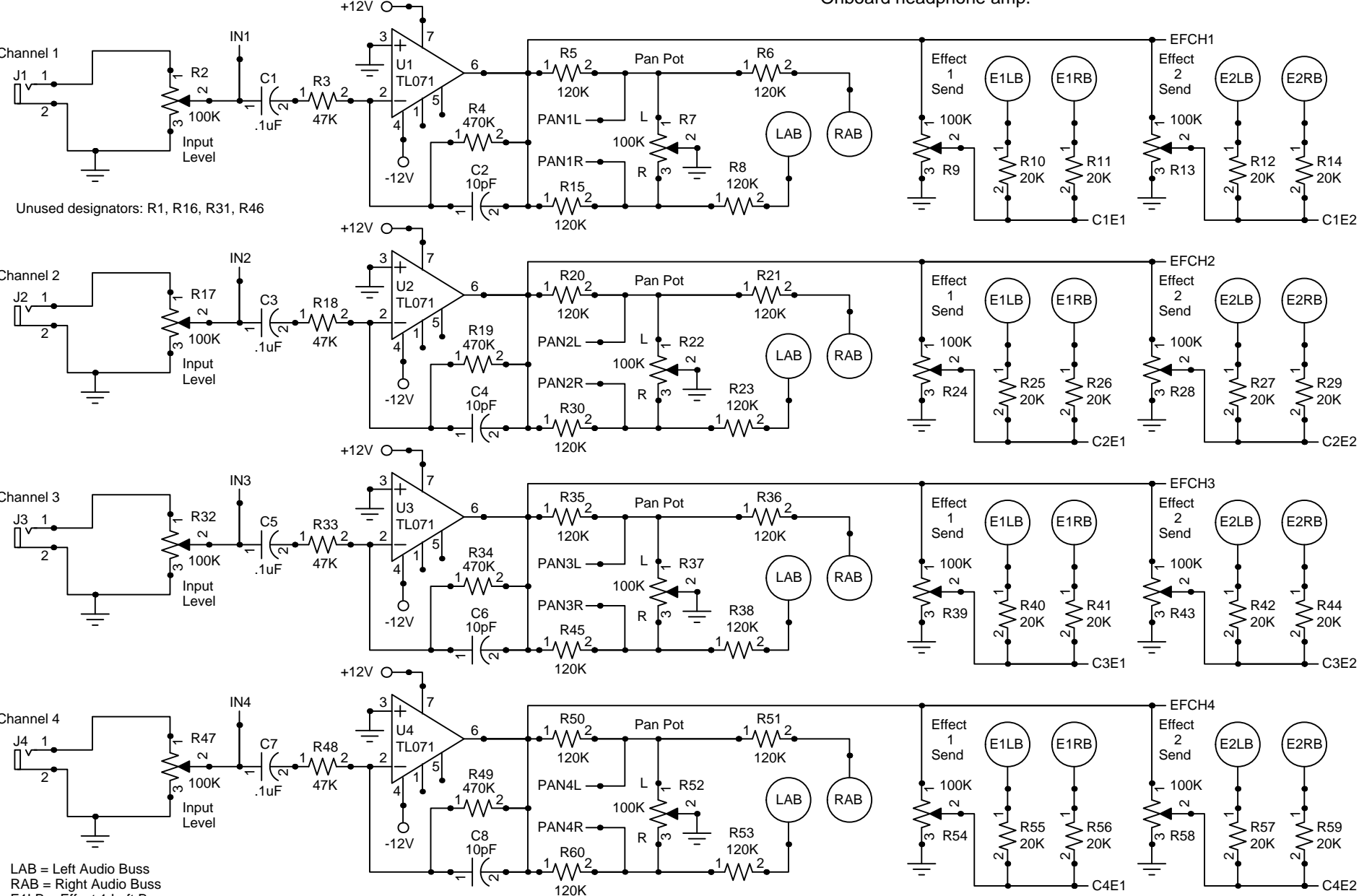

Unused designators: R1, R16, R31, R46

- LAB = Left Audio Buss
- RAB = Right Audio Buss
- E1LB = Effect 1 Left Buss
- E1RB = Effect 1 Right Buss
- E2LB = Effect 2 Left Buss
- E2RB = Effect 2 Right Buss

All buss designators with the same name are connected to one another.

To change a channel's gain change the feedback resistor in it's input buffer. Higher for higher gain and lower for lower gain. For example the feedback resistor for channel 1 is R4. Input buffer gain is 10 as shown.